

10.1" Rugged Tablet PC

M101BL

Product Features:

- 10.1" 1280 x 800 IPS LED Panel with P-Cap Touch
- Long battery life with Intel® BayTrail-M processor
- IP65 water and dust proof
- Optional Barcode or RFID Reader
- Dual Camera Design: 5MP Main camera with LED flash / 2MP Webcam
- Optional Expansion port for USB / RS232 connection
- Replaceable Battery Design / Optional high capacity battery pack
- 2 Programmable function keys
- With Optical Bonding for sunlight readability



Product Specifications:

System Specification	Processor	Intel BayTrail-M Quad-Core 1.8GHz
	System Memory	4GB SODIMM DDR3L-1600 (up to 8GB)
	Storage	64GB mSATA MLC SSD (up to 256GB)
Operating System	Operating System	Windows 10 IoT Enterprise Windows Embedded 8.1 Industry Pro Windows Embedded Standard 7 Windows 7 Pro for Embedded Systems
	Size / Technology	10.1-inch LED backlight
	Resolution	1280 x 800 WUXGA
	Brightness	300 nits typ. With Optical Bonding for Sunlight Readability
Display Specification	Touch	Multi-Touch Projective Capacitive
	Contrast Ratio	800:1
	Wireless Communication	WLAN 802.11 a/b/g/n Bluetooth Bluetooth 4.0 Dual Mode (Classic + Low Energy) Class I GPS u-Blox Neo-6Q WWAN Optional 4G (LTE,HSPA+,GSM/GPRS/EDGE,EV-DO Rev A, 1xRTT) or optional 3G (HSPA+,GSM/GPRS/EDGE)
System I/O Buttons Indicators Sensors Security	Audio	1 x Built-in Mic, 2 x 1W Speaker
	External I/O	1 x Micro HDMI (optional), 1 x 30-pin Combo Conn (Giga-LAN or RS232), 1 x USB3.0, 1 x Audio Combo Conn. (Mic in / Line Out), 1 x Power Jack, 1 x Micro SD Slot
	Buttons	1 x Power, 1 x Home, 2 x Programmable Function Key, 2 x Volume Key
	LED Indicators	Power, Battery, HDD, RF
	Sensors	Light sensor, G sensor, Gyrometer, E-compass
	Security	Password security for user and hard disk lock Kensington lock slot Trusted platform module (TPM) V1.2
Data Capture	Camera	5MP Auto-Focus Camera with LED Flash at rear / 2MP Camera at front side
	Barcode	Short range 1D/2D Barcode Reader (optional) (may not be used with HF RFID)
	RFID	HF RFID Reader (optional) (may not be used with Barcode)
Mechanical and Environment	Dimension (W x L x H)	271.8 x 197.2 x 19 mm (10.7 x 7.76 x 0.75 inches)
	Weight	1.2 kg (2.7 lbs) with standard battery, 1.4 kg (3.1 lbs) with optional high capacity battery
	Operating Temperature	-20°C to 60°C (AC mode), -10°C to 50°C (Battery mode)
	Storage Temperature	-30°C to 70°C (-22°F to 158°F)
	Humidity	10 to 90% RH, non-condensing
	IP Proof	IP65
	Shock	MIL-STD-810G Method 516.6 Procedure I
	Vibration	MIL-STD-810G Method 514.6 Procedure I
	Drop	MIL-STD-810G Method 516.6, 4 ft to concrete *
	Certifications	CE, FCC, IC, UL 60950,
Power Management	Power Input	12-19V DC
	Battery	7.4V, typ. 5300 mAh, min. 5140 mAh Li-Polymer Battery (2S1P) 7.4V, typ. 10600 mAh, min. 10280 mAh Li-Polymer Battery (2S2P, optional)
	Battery Operating Time	Std. Battery: 8 hours*** High Capacity Battery: 16 hours***
	Adapter	100-240V, 50-60Hz / 19V DC

Dimensions :

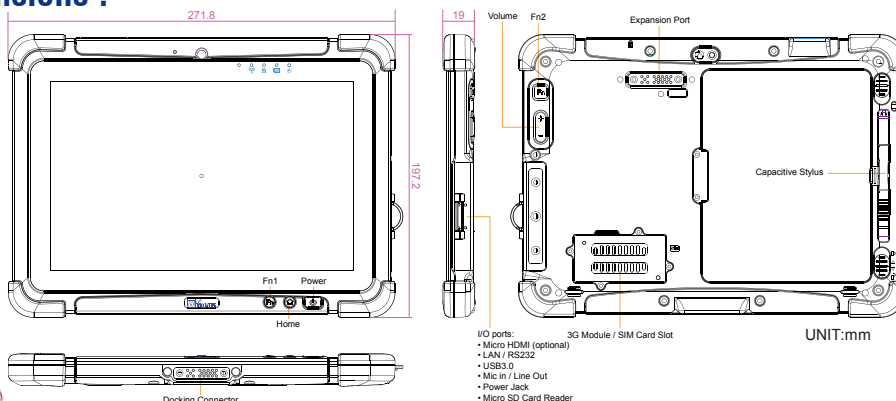

- * Note: The drop test with high-capacity battery must come with hand strap.
- ** Note: Measured at dimming LCD brightness. Varies depending on the usage conditions, or when an external device is attached.
- *** Note: this is a simplified drawing and some components are not marked in detail.
Please contact our sales representative if you need further product information.
- **** Note: All Specifications are subject to change without prior notice.

Accessories:	
1.	19V 65W Power Adapter x 1
2.	Power Cord x 1
3.	Standard Battery x 1
4.	M101 Quick Start Guide x 1
5.	Manual & Driver CD x 1
6.	Capacitive Stylus x 1

Order Information:	
M101BL	Basic
M101BL-3	3G
M101BL-LE	4G/LTE for Europe
M101BL-LA	4G/LTE for North America